

Accuride Wheel Nomenclature

Offset vs. Inset/Outset

For both steel and aluminum commercial vehicle wheels, the following terminology is standard in the industry. To sound like the experts, use this as a reference in all your wheel discussions.

Any wheel that is capable of being assembled in a dual wheel application utilizes the **offset** measurement. An inset or outset is utilized when a wheel cannot be used in a dual application. **Inset** is when the wheel centerline is inboard of the hub/drum mounting surface. When the wheel centerline is outboard of the hub/drum mounting surface that is the **outset**.

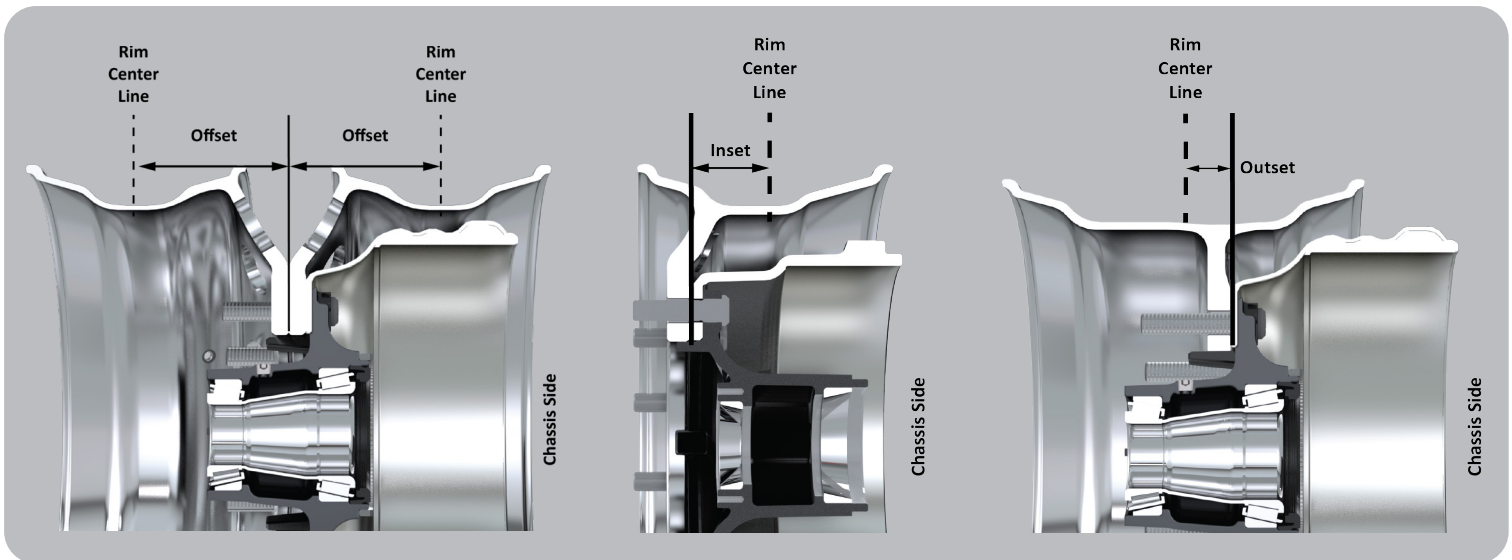

Wheel Nomenclature

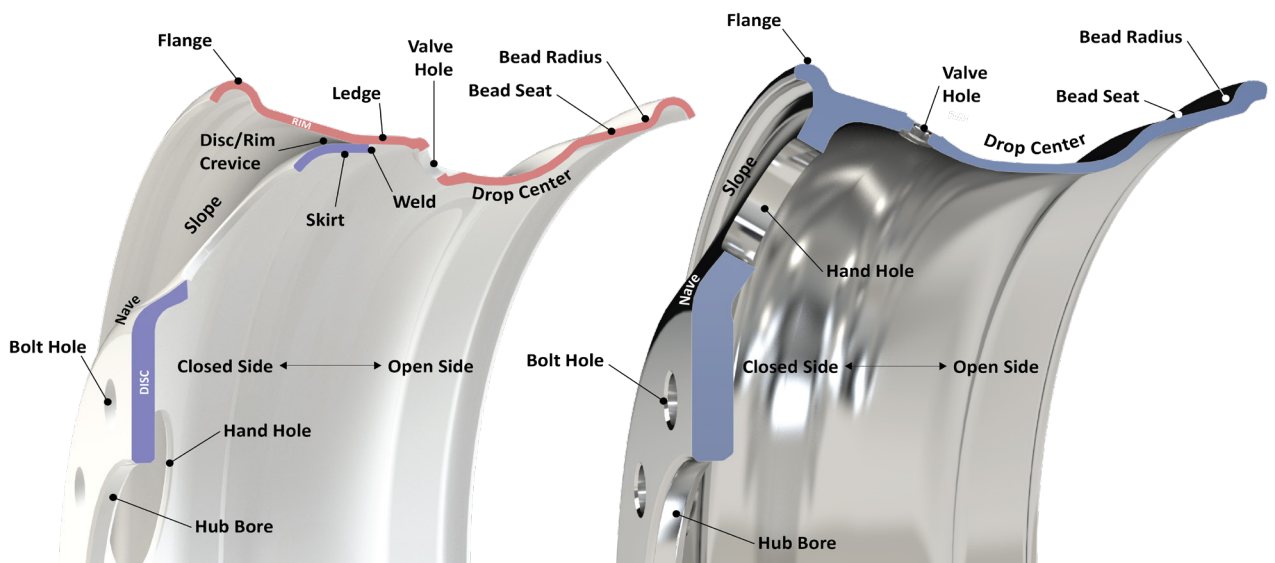

Your only single source for industry-leading wheel end solutions.

STEEL & ALUMINUM WHEELS | DRUMS | HUBS | ROTORS | SLACK ADJUSTERS

For more information: (812) 962-5000 | accuridecorp.com

Accuride | 38777 Six Mile Road, Suite 410 | Livonia, MI 48152 USA

